

The Ripple Maker **Instruction Manual**

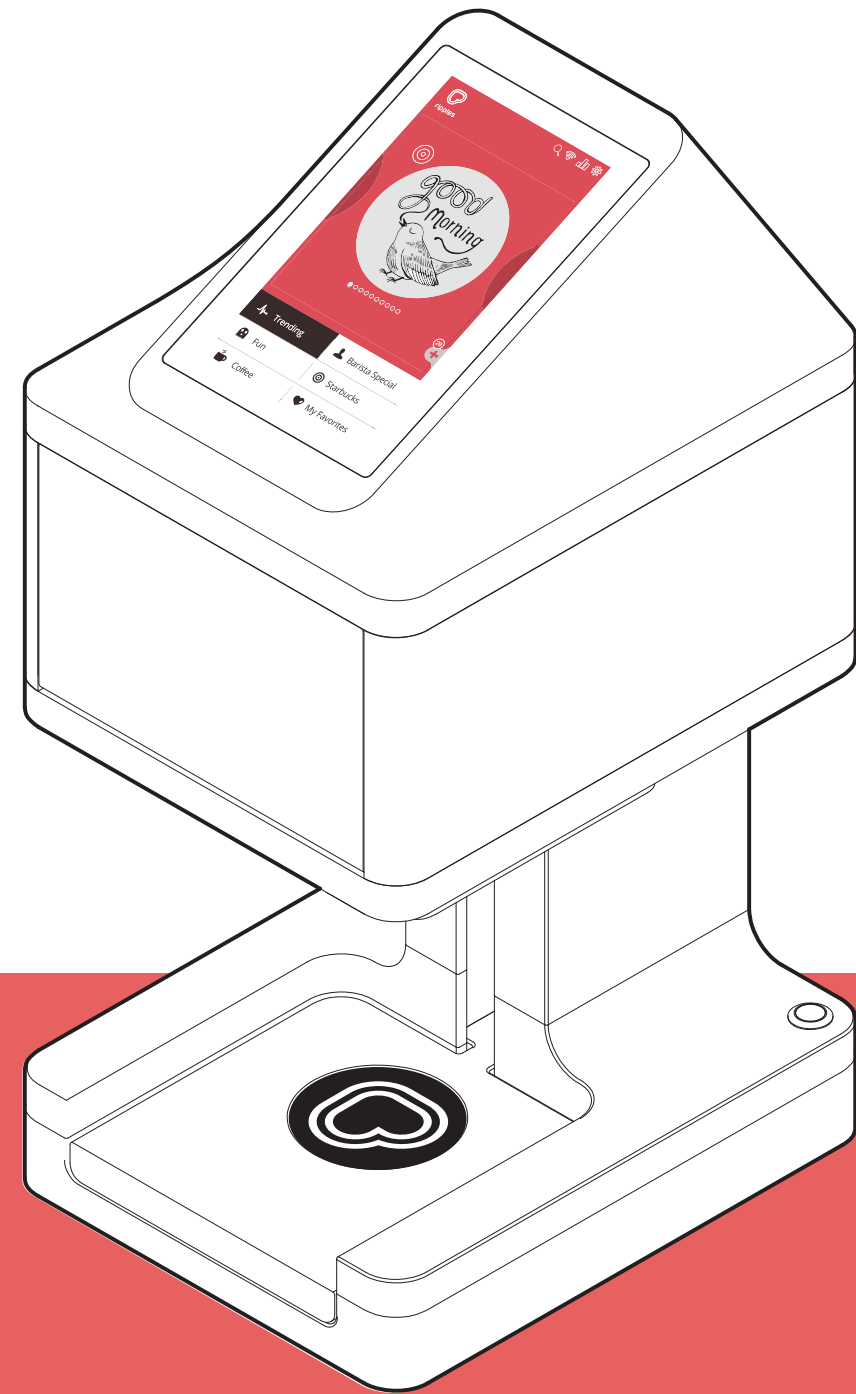

Table of Contents

1.	Important Safety Warnings and Cautions	3
1.1.	Safety Warnings	3
1.2.	Caution	3
2.	Unpacking Instructions	4
3.	Contents of the Box	4
4.	Getting to Know the Parts of the Ripple Maker	5
5.	Setting Up the Ripple Maker	6
5.1.	Placement in the Shop	6
5.2.	Power and Internet Connection	6
5.3.	Setting Up and Using the Ripple Maker User Interface	7
6.	Setting Up the Content Library	9
6.1.	Choosing Content from the app.coffeeripples.com Website	9
7.	Printing your Ripples	9
7.1.	Placement and Orientation of the Coffee Cup	10
7.2.	Choosing a Design and Printing	10
8.	Maintaining the Ripple Maker	11
8.1.	Replacing the Pod	11
8.2.	Cleaning the Ripple Maker	11
9.	Relocating/Transporting the Ripple Maker	13
10.	Technical Specifications	16
11.	Troubleshooting	16
12.	Customer Support	17
13.	General Product Safety Instructions	18
14.	FCC Statement and Declaration of Conformity	19

Table of Figures

Figure 3.1	Contents of the Box	4
Figure 4.1	Ripple Maker Front View	5
Figure 4.2	Ripple Maker Back View	5
Figure 4.3	Drip Tray View	5
Figure 5. 1	Plug in and Turn on the Ripple Maker	6
Figure 5.2	Wi-Fi Setup Screen	7
Figure 5.3	Registration Screen	7
Figure 5 4	Account Confirmation Screen	7
Figure 5.5	User Agreement Screen	8
Figure 5.6	Home Screen	8
Figure 7. 1	Placement and Orientation of Coffee Cup	10
Figure 7.2	Foam Height Illustrations	10
Figure 7. 3	Main Menu	10
Figure 7. 4	The Mobile Queue	11
Figure 7. 5	The Mobile Queue Tab	11
Figure 8. 2	Raise Tray for Cleaning	14
Figure 8. 3	Clean Drip Tray	14

Table of Tables



Table 1. 1	Descriptions of Warning and Caution Symbols used in this Instruction Manual	3
Table 10. 1	Technical Specifications	16
Table 12. 1	List of Instructional Videos	18

01 Important Safety Warnings and Cautions

Follow these basic precautions when using the Ripple Maker to avoid electric shock, injury to persons, risk of fire and damage to the Ripple Maker.

Table 1.1

Descriptions of Warning and Caution Symbols used in this Instruction Manual

Symbol	Description
	Warning: indicates actions or situations that could cause electric shock, fire, injury or damage to the Ripple Maker.
	Caution: indicates actions or situations that could cause damage to the Ripple Maker or its operator.



1.1 Safety Warnings

1. Read All Instructions.
2. Do not place the Ripple Maker, its cord or plug, in water or other liquids. The Ripple Maker is water-resistant only.
3. Do not handle the cord or plug with wet hands.
4. Do not place the Ripple Maker in contact with hot surfaces.
5. Keep the Ripple Maker away from extreme temperatures and do not place in direct sunlight.
6. The Ripple Maker contains moving parts. Avoid placing body parts close to printing areas to avoid injury.
7. Always turn off and unplug the Ripple Maker from the electrical outlet before cleaning or as instructed in section 8.
8. Do not operate the Ripple Maker if its cord or plug are damaged or if the Ripple Maker is malfunctioning. Call Customer Support for help. See section 12 for details.
9. Use cleaning materials and liquids recommended by Steam CC (see section 8.2). Not doing so may cause injury, fire, electric shock or damage to the Ripple Maker and will void the warranty.
10. Keep your hair and jewelry away from the Ripple Maker.
11. In case of an emergency, unplug the Ripple Maker.
12. Do not open the back service door. This action is dangerous and will void the warranty.
13. Keep fingers away in normal use, covers closing - pinching possible.



1.2 Caution

1. The Ripple Maker is designed to print on foam surfaces only, please do not use this device for any other purpose.
2. The manufacturer will not be responsible for misuse or mistreatment of the Ripple Maker.
3. The use of cartridges other than the original provided by Steam CC is forbidden, since this may cause damage to the Ripple Maker and will void the warranty.

02 Unpacking Instructions



03 Contents of the Box

This section lists the items that are in the Ripple Maker package. Check carefully to make sure you have all items on the list.

- 1 Ripple Maker
- 2 Pods
- 1 Power Cord and AC adaptor
- 1 Wi-Fi Dongle
- Instruction Manual
- Drip Tray

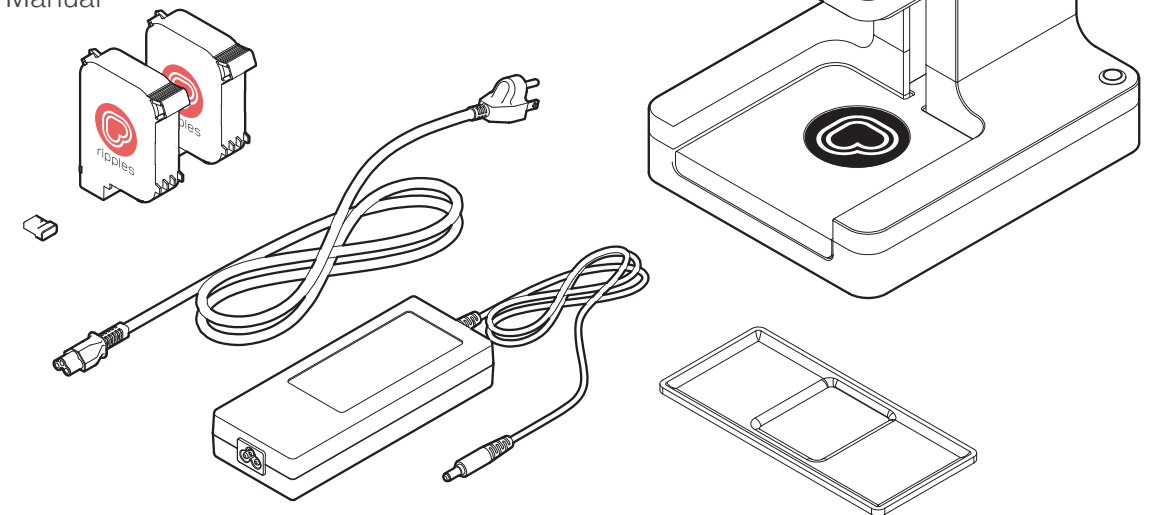

Figure 3.1: Contents of the Box

04 Getting to Know the Parts of the Ripple Maker

This section illustrates the different parts of the Ripple Maker.

1. Touch Screen Display
2. Lid
3. Front Door
4. On/Off Button
5. Tray
6. Plug for Power Cord
7. Ethernet Port
8. Wi-Fi Dongle USB Port
9. Drip Tray

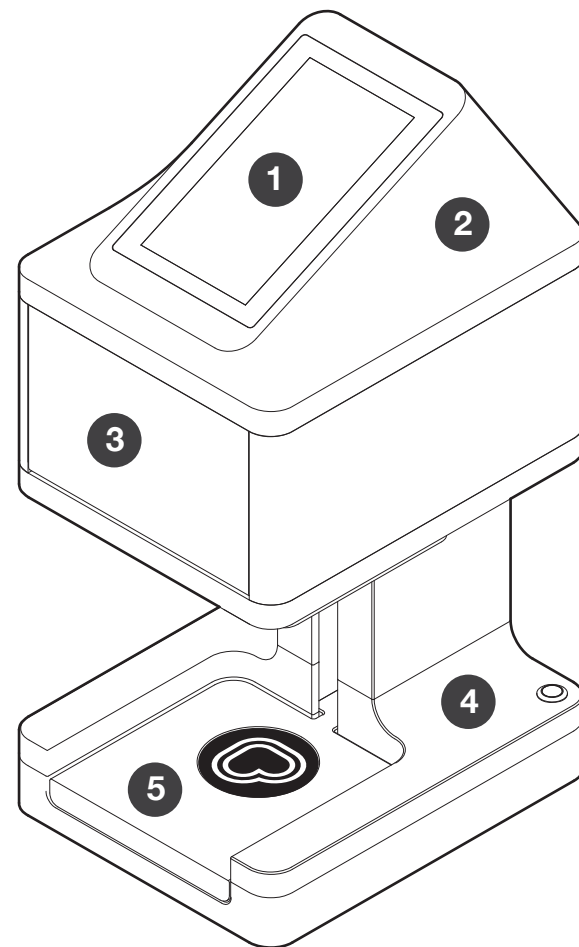

Figure 4.1: Ripple Maker Front View

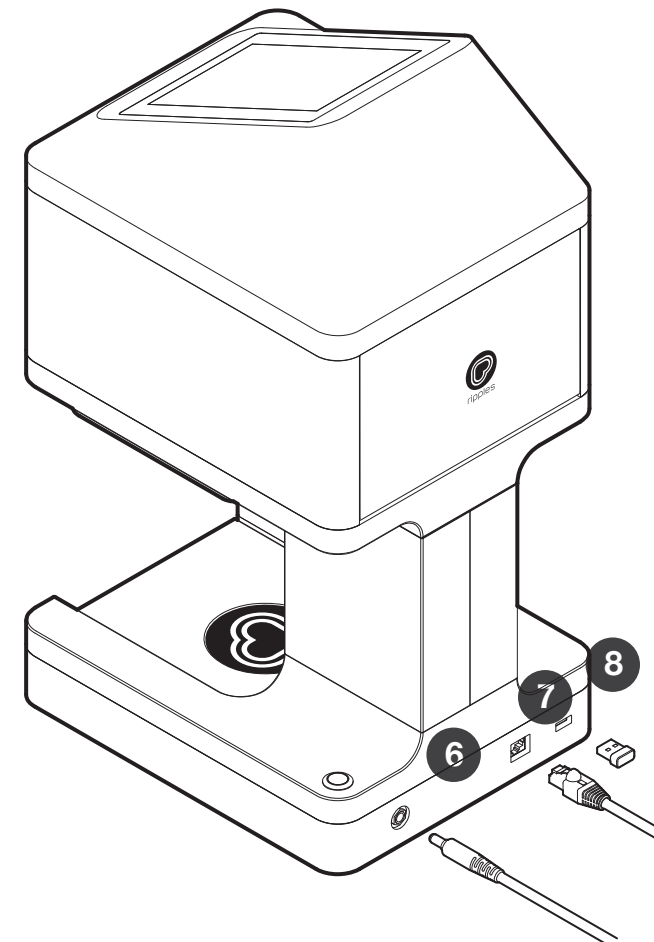

Figure 4.2: Ripple Maker Back View

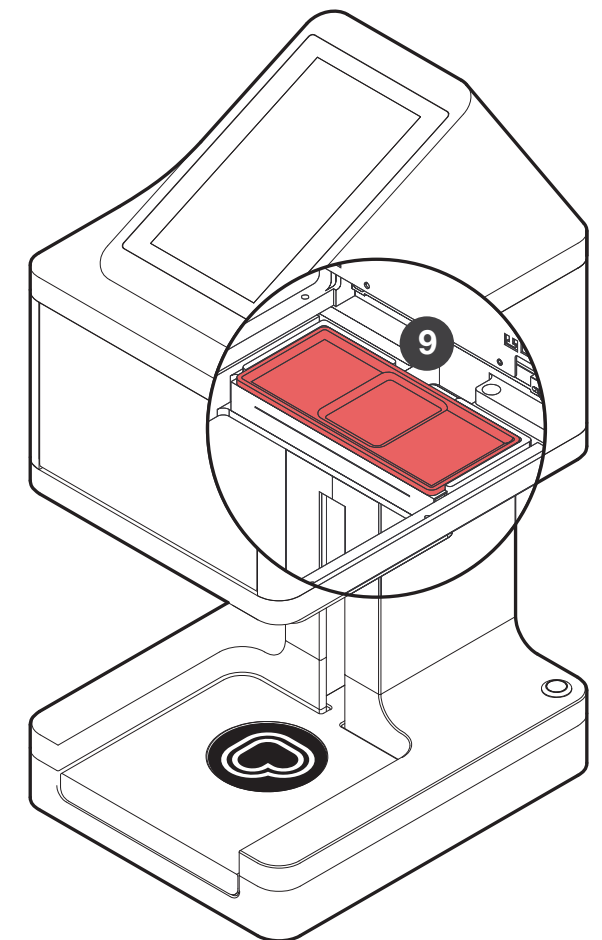

Figure 4.3: Drip Tray View

05 Setting Up the Ripple Maker

Thank you for purchasing the Ripple Maker! Now you can print any text, design or even photograph on top of every latte and cappuccino for the enjoyment of your customers.

This section includes information about:

- Where to place the Ripple Maker in your shop
- Connecting to AC power
- Inserting the Wi-Fi dongle or Ethernet cable
- How to navigate the user interface



For a video on the subject go to the app.coffeeripples.com website and view the "Quick Start" video.

5.1 Placement in the Shop

When searching for a suitable location for the Ripple Maker in your shop, use the following guidelines:

- Place the Ripple Maker in accordance with the safety instructions. See Section 1 for more details.
- Install close to an electrical outlet.
- Place the Ripple Maker on a level surface.
- Position the Ripple Maker in a convenient location for the barista, keeping in mind the work flow of the barista and other people.
- Make sure the Ripple Maker is placed next to an Ethernet outlet or where there is good Wi-Fi signal.
- Ensure that the front of the Ripple Maker is facing the barista.

5.2 Power and Internet Connection

1. Connect the power cord (A) to the power input located at the back of the Ripple Maker. Plug the other end into the wall outlet.
2. Unbox the Wi-Fi dongle and insert it in to the USB port at the bottom of the Ripple Maker or connect an Ethernet cable to the Ripple Maker.



Follow safety instructions regarding the AC connection. See section 1 for more details.

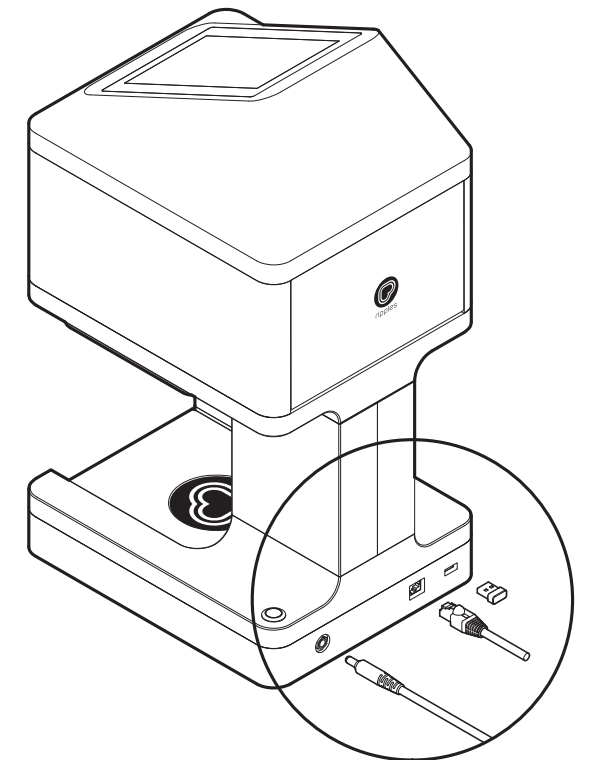
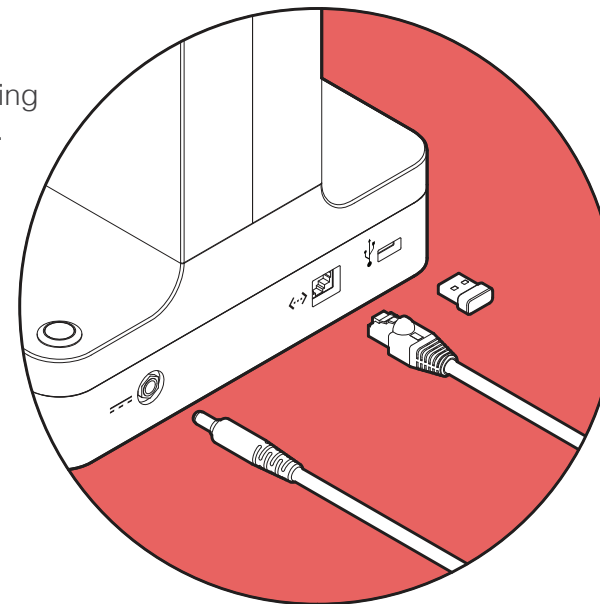

Figure 5.1: Plug in and Turn on the Ripple Maker



Be sure that the Ripple Maker is placed on a stable and strong enough surface to support the Ripple Maker. ⁶

5.3 Setting Up and Using the Ripple Maker User Interface

The first time you are operating the Ripple Maker you need to set up the Ripple Maker user interface.

Follow the steps listed below to complete the setup:

01

Switch on the Ripple Maker by pressing the On/Off button at the base of the Ripple Maker and wait for the system to boot up.



Important: Never turn off your Ripple Maker unless instructed otherwise. This will deny automated maintenance procedures and will damage the Ripple Maker.

02

Select your Wi-Fi connection.

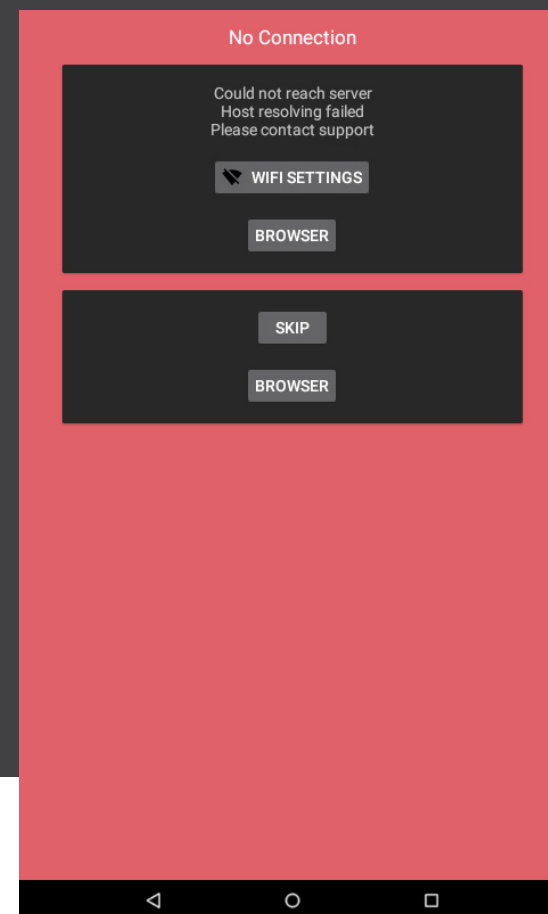

Figure 5.2: Wi-Fi Setup Screen

03

Please wait while the machine is being registered.

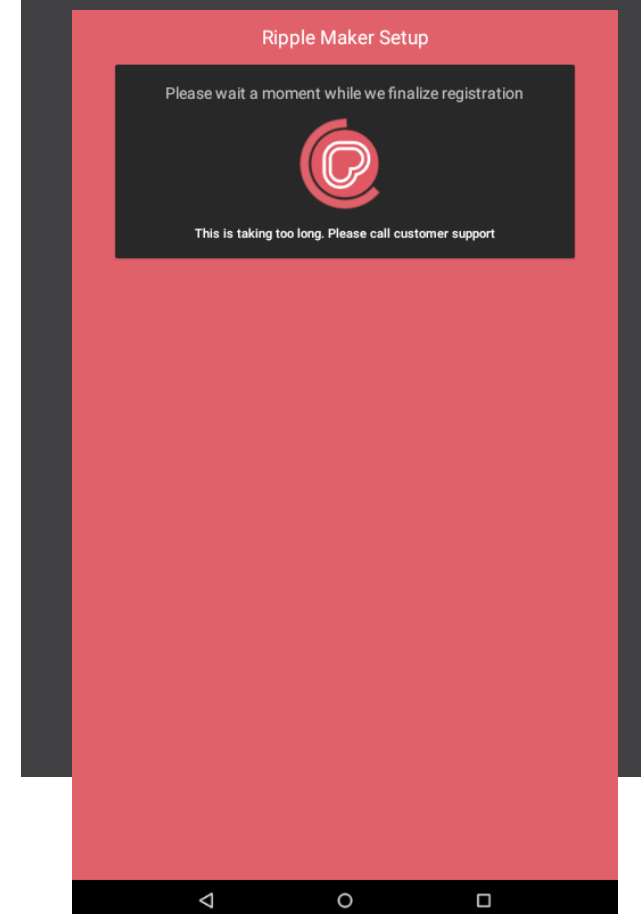

Figure 5.3: Registration Screen

04

Confirm your location and ownership.

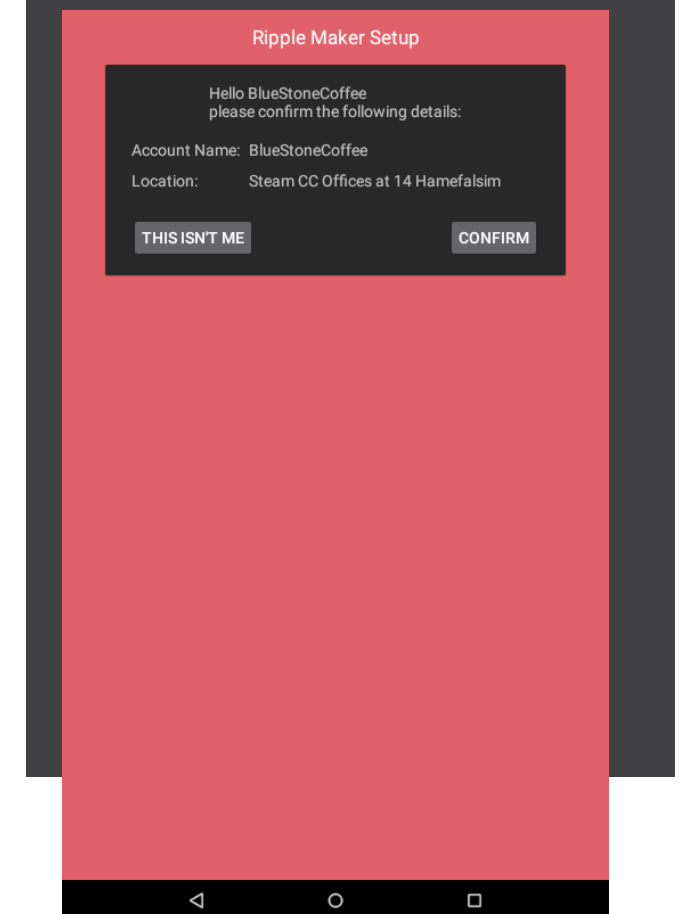

Figure 5.4: Account Confirmation Screen ⁷

05

The User Agreement is displayed on screen. Please accept the agreement.

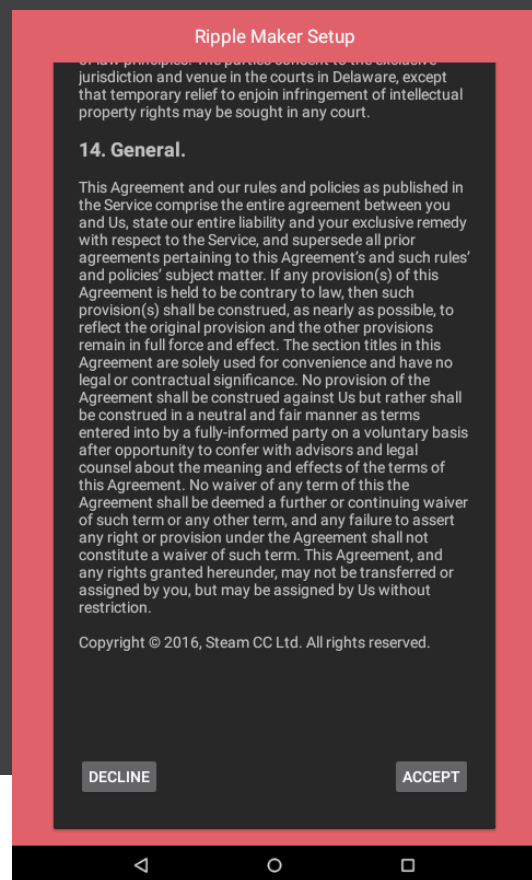

Figure 5.5: User Agreement Screen

06

Tap the "START" button and start using the Ripple Maker.

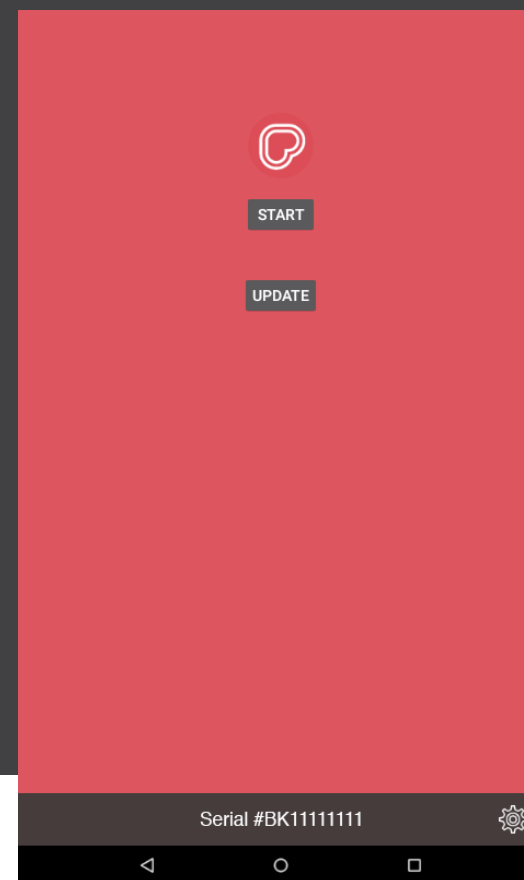

Figure 5.6: Home Screen

07

Since this is your first time operating the Ripple Maker please see:

1. Chapter 8.1 "Replacing the Pod" in order to install a new pod.
2. Chapter 8.2.4 "Cleaning the Drip Tray" in order to install the drip tray.

06 Setting Up the Content Library

The Content Library contains all of the Ripples that you can print. This section explains how to edit your Content Library using the web app.

6.1 Choosing content from the app.coffeerripples.com website

Your content library already contains the basic themes and Ripples provided by Steam CC. You can also download more Ripples and create your own.

1. To choose or create additional designs to use with the Ripple Maker, go to the app.coffeerripples.com website.
2. Log in using your email and password, if you don't know your account details please contact your system admin or your local manager.
3. On the side menu select "Ripples" and hit "New Ripple" on the right upper corner of the screen.
4. Now you can add any JPEG or PNG image you like by clicking the "Add image" button. We recommend using high contrast images with bold lines.
5. Choose a name for your Ripple and hit "Create" on the bottom right side of the screen.
6. Now that you have created a new draft Ripple you need to submit it to your personal theme. Under "Drafted Ripples" find your newly created Ripple, hover with the pointer over the Ripple image and click the "Setting" icon, then "Submit Ripple" and finally "Submit".
7. Now all that is left is to approve (or reject) the submitted Ripple. This can only be done by the brand administrator. Find your submitted Ripple under "Pending", click the "Setting" button then hit "Approve",
8. Your new Ripple is created and will be synced to your Ripple Maker's content library in a few short minutes.



Any rejected Ripple will stay under "Rejected Ripples" until it's deleted.



Watch the "Creating your own Ripples" video to learn more on the subject.

07 Printing your Ripples

Printing is simple and follows these steps:



For a how-to video please go to the app.coffeerripples.com website and view the "Preparing to Ripple" video.



Make sure you follow the instructions in this section carefully in order to prevent damage to the Ripple Maker or injury to persons.

7.1 Placement and Orientation of the Coffee Cup

Place the cup in the center of the circle on the tray.
It is very important to use cups that are not larger than 4.25in/110mm (outer diameter) and that the handles of the cup are no higher than the lip of the cup, as shown in below.

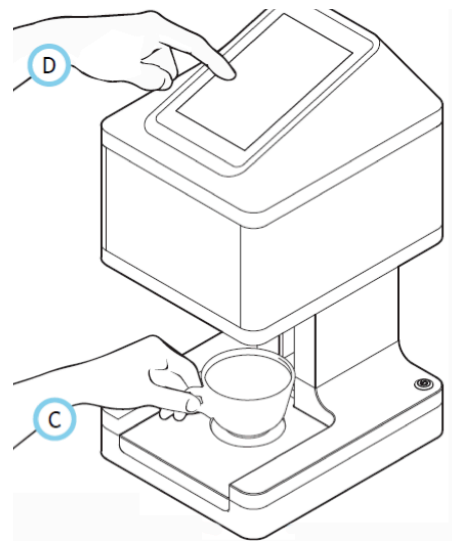

Figure 7.1: Placement and Orientation of Coffee Cup

7.1.2 Foam Height Guidelines

The following illustrations show how the foam itself should be poured into the coffee cup

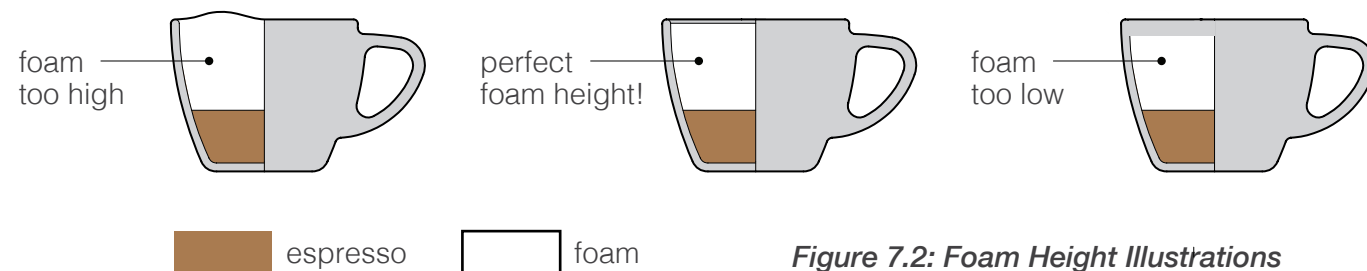

Figure 7.2: Foam Height Illustrations



1. **Not following these instructions could cause damage or injury.**
2. The cup may contain a hot drink, therefore pay close attention to the start of the printing and collect the cup immediately after the printing is completed.

7.2 Choosing a Design and Printing

7.2.1 Fast Print

1. Choose the desired category from the bottom menu. The Ripples that belong to that category will now be displayed.
2. Choose a Ripple by swiping it left or right then tap on it in order to print it.

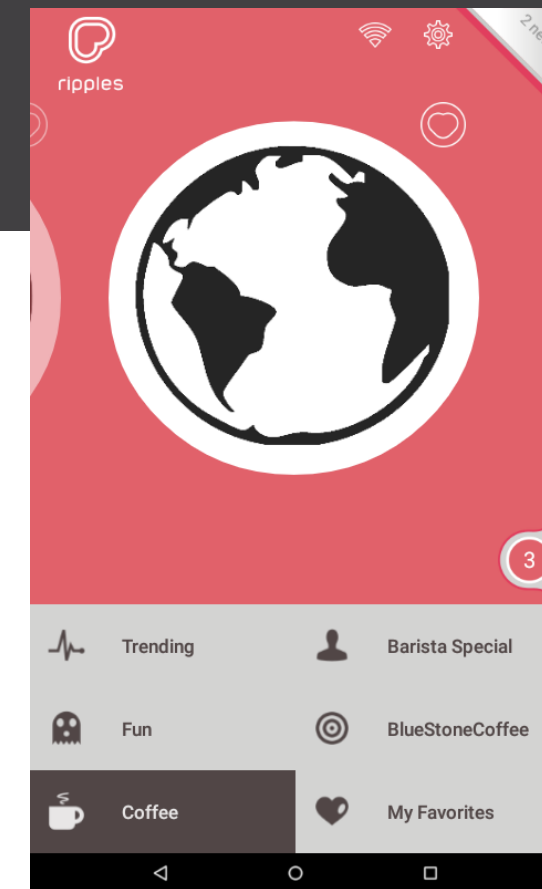

Figure 7.3: Main Menu



This will immediately initiate the printing process.

7.2.2 Printing your customer's Ripples

1. Open the Mobile queue by tapping on its tab, located at the right side of the screen, just above the category menu.
2. Tap the ticket number on The Mobile Queue that corresponds to the ticket number provided by the customer's mobile app.
3. Tap on your customer's Ripple in order to print it.



Figure 7.4: The Mobile Queue

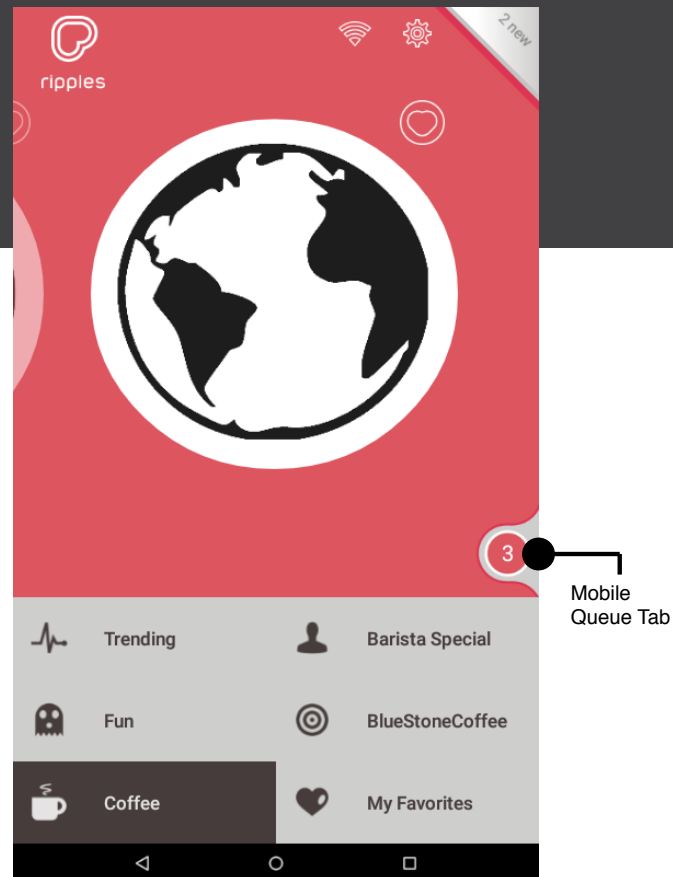



Figure 7.5: The Mobile Queue Tab

Important:

- The Mobile Queue contains orders for Ripples sent by your customers from their mobile phone to your Ripple Maker.
- To delete a single mobile Ripple from The Mobile Queue, tap the Ripple number in the queue and hold briefly until the Ripple is removed.
- To clear The Mobile App Queue, tap  to display the Settings screen than tap **Clear Mobile Queue**.

08 Maintaining the Ripple Maker

This section contains maintenance and cleaning instructions. Please follow these instructions carefully in order to prevent injury or damage.



Please see Cautions and Warnings in Section 1 before performing any maintenance. This section describes only those procedures that the user is allowed to perform. Any other maintenance, especially involving the use of tools, must be performed by a qualified person certified by the manufacturer/authorized distributor.

8.1 Replacing the Pod



1. Do not touch the copper contacts or the nozzles on the new pod.
2. The process requires an empty tray.

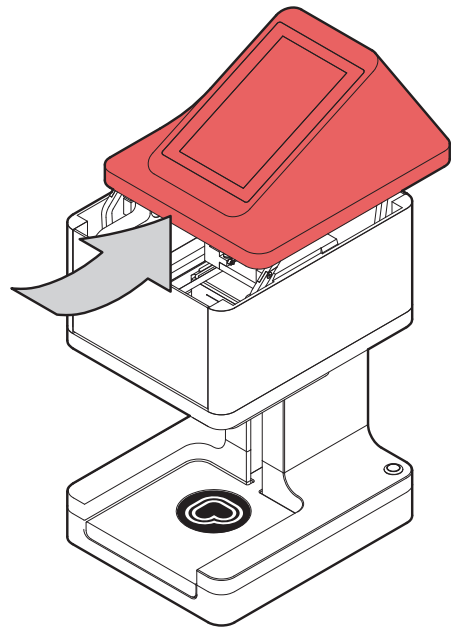

4 Gently lift the lid of the Ripple Maker.

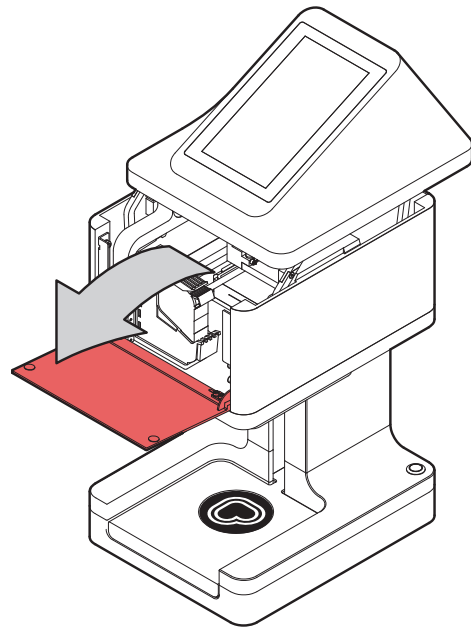

5 Open the access door of the Ripple Maker.

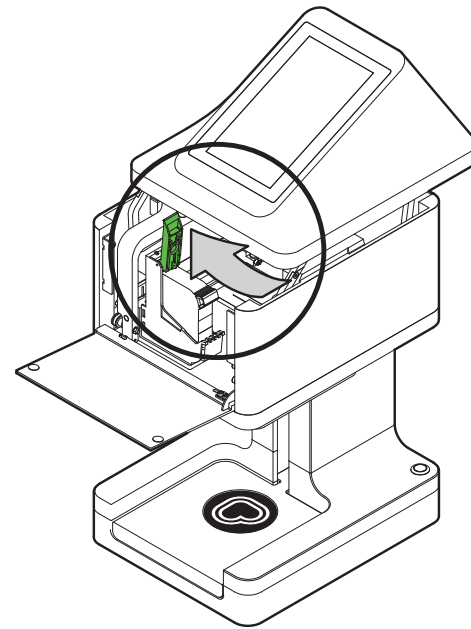

6 Lift the green latch securing the pod.

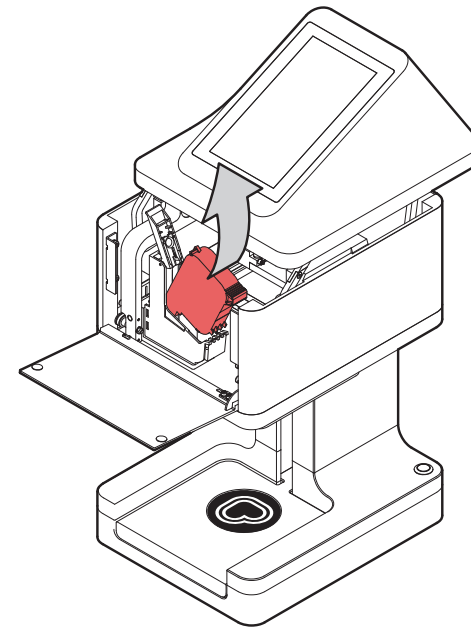

7 Remove the pod by wiggling it upwards and out with your fingers.

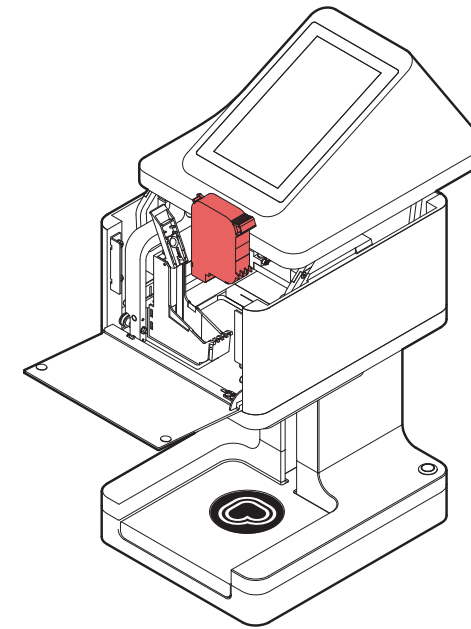

8 Unpack the new pod and insert it into place.

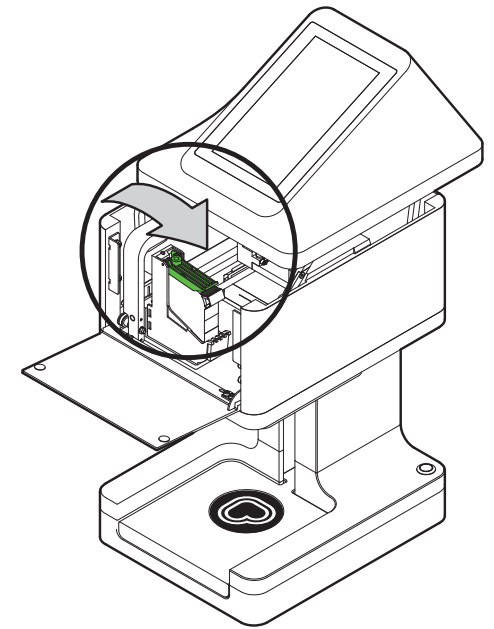

9 Secure the latch over the new pod by pushing it down until you hear a click.

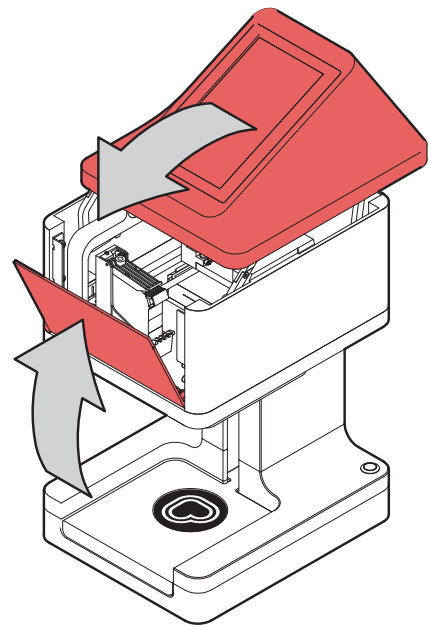

10 Close the access door and then return the lid to its proper position.

11 Tap **DONE** on the Ripple Maker screen once you have finished all of the above.

8.2 Cleaning the Ripple Maker

Proper cleaning is necessary to ensure the functioning of the Ripple Maker.

 **YouTube**

A how-to video is available at app.coffeeripples.com website, "Cleaning the Ripple Maker."

8.2.1 How often to clean the Ripple Maker

Clean the Ripple Maker at the end of each work day, pay special attention to the drip tray. If not specified otherwise use a damp cloth only.

8.2.2 Cleaning the outside of the Ripple Maker

1. Turn off and unplug the Ripple Maker from the electrical outlet.
2. The Ripple Maker is water resistant only. Keep the Ripple Maker away from water.
3. Clean the outside of the Ripple Maker.



8.2.4 Cleaning the Drip Tray

The drip tray is a metal piece inside the Ripple Maker that collects drops of coffee from the pod.

8.2.3 Cleaning the Tray

1. Turn the Ripple Maker back on.
2. Go to the Preferences menu and tap **Raise Tray for Cleaning**.
3. Clean the surface of the tray.
4. Clean under the tray.
5. Tap **DONE** on the Ripple Maker screen once you have finished all of the above. The tray returns to its resting position.

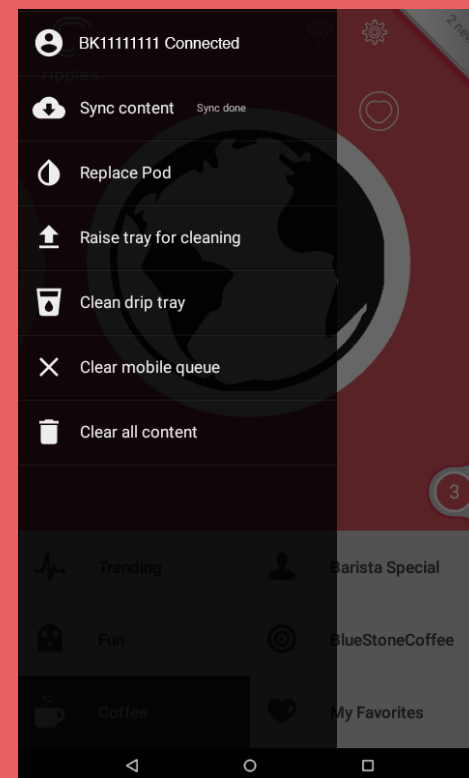

Figure 8.2: Raise Tray for Cleaning

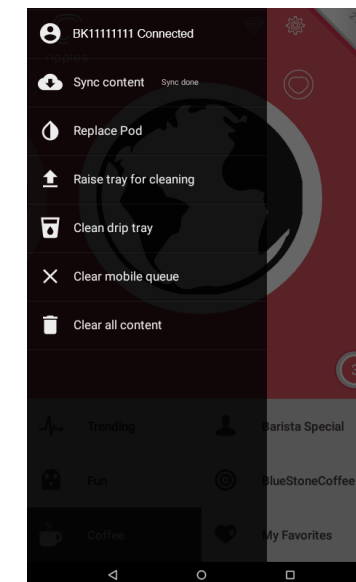
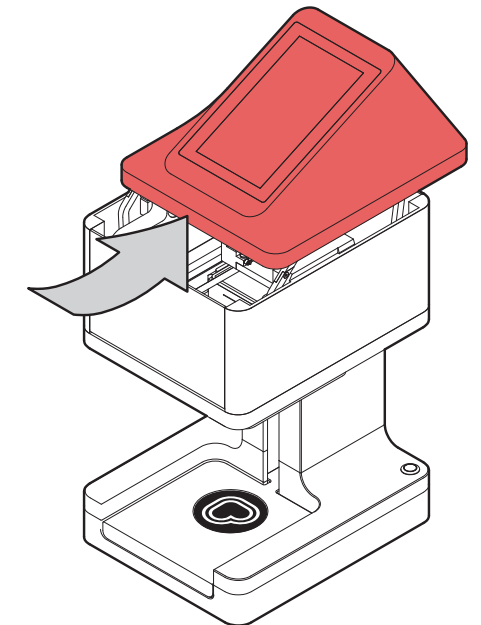



Figure 8.3: Clean Drip Tray



1 Tap the  **Preferences** button.

2 Tap **Clean drip tray**. The pod will move into position.

3 Lift the lid of the Ripple Maker.

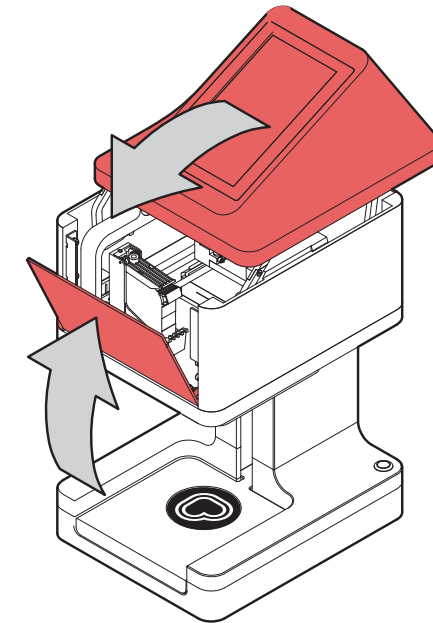
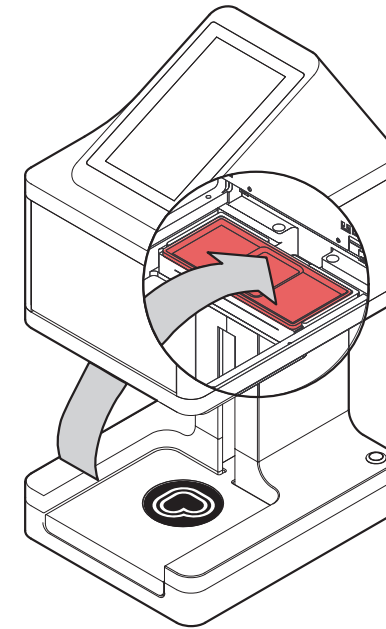
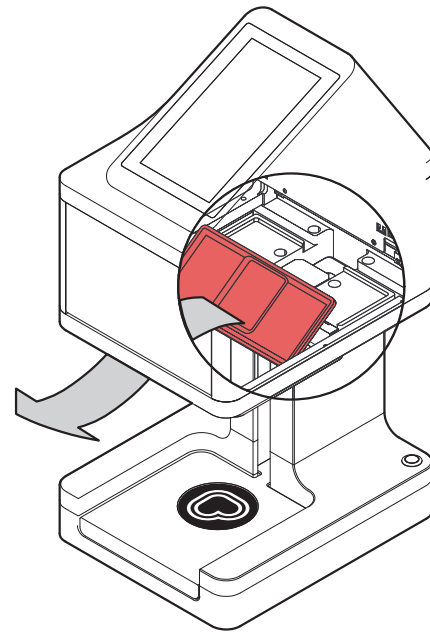
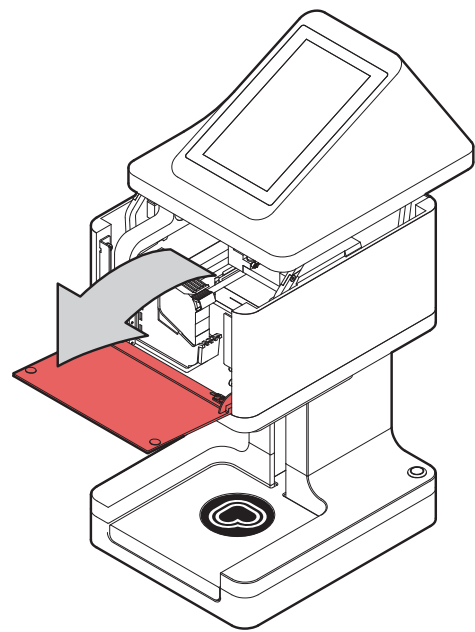

4 Open the access door.

5 Slide out the drip tray.

6 Clean the drip tray with warm water. If necessary, clean the area underneath the drip tray as well.

7 Dry the drip tray and slide the tray back in.

8 Close the access door and then return the lid to its proper position.

9 Tap **DONE** on the Ripple Maker screen once you have finished all of the above.

09 Relocating/Transporting the Ripple Maker

You may need to transport the Ripple Maker to a different place at your current location or to another distant location. This section describes how to transport the Ripple Maker for a long distance.



During transportation and storage, use the following guidelines:

1. Avoid tilting the product, placing it horizontally, or turning it upside down.
2. Leave the pod installed.
3. Turn off the Ripple Maker.
4. Unplug the power cable.
5. Disconnect any connected cables.
6. Place the product in its original packing materials, if possible. You may also use equivalent materials that cushion the Ripple Maker. Make sure the box adequately protects the Ripple Maker's Touch Screen Display.
7. Keep the Ripple Maker level during transport.
8. For assistance on how to set up the new location of the Ripple Maker at app.coffeeriipples.com please contact customer support.

10 Technical Specifications

Table 10.1: Technical Specifications

Environmental specifications	Operating environment	Operating temperature: 10° to 40° C
		Recommended operating conditions: 15° to 32° C
		Recommended relative humidity: 25 to 75% noncondensing
	Storage environment	Storage temperature: -40° to 60° C
Storage relative humidity: Up to 90% noncondensing at a temperature of 65° C		
Electrical specifications	Power supply	Universal power adapter (external)
	Power requirements	Input voltage: 100 to 240 VAC (± 10%), 50 to 60 Hz (± 3Hz)
		Output voltage: 24 Vdc, 4000 mA
Power consumption	100 watt	
Acoustic emission specifications	Sound pressure (bystander position)	LpAd 55 (dBA)
	Sound power	LwAd 6.7 (BA)
Physical specifications	Width	8.5in / 210mm
	Depth	10in / 270mm
	Height	19.5in / 495mm
	Weight	35lbs / 16kg

11 Troubleshooting

1# My Ripple Maker won't turn on

Please verify:

- That all of the power connections are firmly connected (Ripple Maker socket, power source socket, wall socket).
- The power light is on, both on the Ripple Maker and the power supply.

Please verify:

- The Ripple Maker is connected to the power supply and the on/off button is pressed.
- The power light is on, both on the Ripple Maker and the power supply.
- The pod is properly placed (as shown in Section 8.1).
- The Ripple Maker's lid is closed.
- The coffee cup is properly placed within the tray.

2#

My Ripple Maker is not printing

3# The touch screen display of my Ripple Maker does not respond

- Press the power button to turn the Ripple Maker off.
- Clean the screen with dry paper, make sure no water drops are on it.
- Press the power button to turn the Ripple Maker back on.

4#

I can't get new Ripples from my online content library or mobile app

- Make sure that the supplied Wi-Fi dongle is connected properly and its blue light is flashing. Only the supplied Wi-Fi dongle will work with the Ripple Maker.
- Make sure that the Ripple Maker is connected to your local Wi-Fi network.
- Press the power button to turn the Ripple Maker off.
- Press the power button to turn the Ripple Maker back on.

5# My Ripple Maker printouts are unclear and blurry

Make sure that the foam is as flat and even as possible.

If using different kinds of milk (like soy and skim) please visit our app.coffeeriipples.com website and view the "Differences in Milk Foam" video.

- For more information visit our app.coffeeriipples.com website and view the "Preparing to Ripple" video.

6# A drink spilled on the Ripple Maker

- Turn of the Ripple Maker and unplug the power cord.
- Use a dry cloth or towel to dry the Ripple Maker.
- If liquids have reached the power outlet or on/off button make sure to dry it carefully. **Contact customer support before resuming usage.**
- If you notice any abnormal function when resuming use of the Ripple Maker turn off and unplug the Ripple Maker and contact customer support.

12 Customer Support

For instructional videos on the following subjects, please go to the app.coffeeriipples.com website.

Table 12.1: List of Instructional Videos

Subject	Name of Video
Setting Up the Ripple Maker	Quick Start
Setting Up the Content Library	Setting Up the Content Library
Printing your Ripples	Preparing to Ripple
Replacing the Pod	Replacing the Pod
Cleaning the Ripple Maker	Cleaning the Ripple Maker

To contact Support:

Contact means	Contact information
Telephone	ISR: 03-7795020
	US: 1-866-477-0775
Web site	coffeeriipples.com
Email	support@steamcc.com

13 General Product Safety Instructions

- Always hold the plug when removing the power cord from or inserting it into the outlet. Do not pull on the cord when removing it from the electrical socket. The wire in the cord may become damaged.
- Do not use included power cord for other products. Do not use a damaged power cord.
- Use only the approved power source (120/240 VAC) and USB cable.
- Unplug the power cord immediately and stop using the Ripple Maker if you notice any abnormal odor, heat, discoloration, deformation or anything unusual while the Ripple Maker is in use or storage.
- Do not remove the power cord from nor insert it into the electrical outlet with wet hands. Be sure to disconnect the Ripple Maker from the power source outlet when not using for any extended period of time.
- Place the Ripple Maker near a standard electrical outlet that is easily accessible.
- Do not place the Ripple Maker in direct sunlight, near heaters or other hot appliances, in any location exposed to extremely high or low temperatures, high humidity, or dusty locations.
- When using the Ripple Maker, place it on a stable desk, shelf, or table.
- Remove all dust/dirt from the Ripple Maker before use.
- Do not insert any objects into or block the output or USB port or the Ethernet port.
- Do not place any heavy objects on top of the Ripple Maker.
- Do not use the Ripple Maker with a foreign object in it.
- If water, metallic substance or any foreign object enters into the Ripple Maker, disconnect the Ripple Maker from the power source, and contact Customer Service.
- Do not disassemble the Ripple Maker.
- For inspection, adjustment, and repair of the Ripple Maker, contact Customer Service.
- Close all covers when operating.
- Do not apply excessive pressure to the Ripple Maker.
- Use only genuine Steam CC accessories and supplies. Do not use any unauthorized accessories or supplies.
- This equipment should not be used by children.
- Children should be supervised to ensure that they do not play with the appliance.
- If the supply cord is damaged, it must be replaced by a special cord or assembly available from the manufacturer or its service agent.
- Read all Instructions.
- To protect against fire, electric shock and injury to persons do not immerse cord, plugs, or Power source in water or other liquid.
- Unplug from outlet when not in use and before cleaning.
- Do not operate with a damaged cord or plug or after malfunction, or if the Ripple Maker has been damaged in any manner.
- Return appliance to the nearest authorized service facility for examination, repair or adjustment.
- Do not let cord hang over edge of table or counter, or touch hot surfaces.
- Do not place on or near a hot gas or electric burner, or in a heated oven.
- Always attach plug to printer first, then plug cord into the wall outlet. To disconnect, turn OFF, then remove plug from wall outlet.
- Do not use for other than intended use.
- The instructions for use shall contain instructions for cleaning of all surfaces coming into contact with food during normal use.
- Instructions for user maintenance, for example cleaning, shall also be given. They shall include a statement that the appliance is not to be cleaned with a water jet.
- Use only a dry, soft cloth to clean the screen. Do not use liquid or chemical cleansers.
- If the screen is damaged, contact customer support.
- Do not press too hard on the screen.
- Do not use a pointy or sharp object, such as a pen or your fingernail, to operate the screen.

14 FCC Statement and Declaration of Conformity

14.1 FCC Statement

This device complies with Part 15 of the FCC Rules.

Operation is subject to the following two conditions:

(1) This device may not cause harmful interferences, and (2) This device must accept any interferences received, including interference that may cause undesired operation.

Note: This equipment has been tested and found to comply with the limits for a class B digital device, pursuant to Part 15 of the FCC Rules. These limits are designed to provide reasonable protection against harmful interference in a residential installation.

This equipment generates, uses, and can radiate radio frequency energy and, if not installed and used in accordance with the instructions, may cause harmful interference to radio communications.

However, there is no guarantee that interference will not occur in a particular installation.

If this equipment does cause harmful interference to radio or television reception, which can be determined by turning the equipment off and on, the user is encouraged to try to correct the interference by one or more of the following measures:

- Reorient or relocate the receiving antenna.
- Increase the separation between the equipment and receiver.
- Connect the equipment into an outlet on a circuit different from that to which the receiver is connected.
- Consult a Steam authorized dealer or service representative for help.

Properly shielded and grounded cables and connectors must be used in order to meet FCC emission limits. Proper cables and connectors are available from Steam CC Authorized Dealers.

Any changes or modifications to the Ripple Maker that are not expressly approved by Steam CC could void the user's authority to operate this equipment.

Use of a shielded interface cable is required to comply with the Class B limits of Part 15 of FCC rules. Steam CC shall not be liable for any direct, indirect, incidental, consequential, or other damage alleged in connection with the furnishing or use of this information.

Steam CC is not responsible for any radio or television interference caused by using other than recommended cables or connectors or by unauthorized changes or modifications to this equipment. Unauthorized changes or modifications could void the user's authority to operate the equipment.



ripples